



Phoenix / Sanitizer / Multi-Fit Gas-Fired Water Heater Submittal Sheet

JOB NAME:

LOCATION:

ARCH./ENGR.:

WHOLESALER:

MECH. CONTRACTOR:

MODEL NUMBER:

TYPE OF GAS:

BTU/HR INPUT LOW – HIGH FIRE:

NOTES:

High Efficiency Heat Exchanger

- Copper Nickel primary with 800 H and Copper Nickel secondary tube construction
- Gasketless heat exchanger design

Combustion System

- Modulating burner with up to 5 to 1 turndown
- Up to 96% thermal efficiency (All Models)
- High-Grade Inconel premix burner
- Spark ignition
- Fires on Natural or LP Gas with included conversion kit
- Dual flame monitoring (Spark and Flame probe)
- Flame stabilization monitoring – Automatic adjustment of firing rate to stabilize flame signal

Uniform Energy Factor (UEF) – 100kBTU Models

- Up to 0.89 UEF –55 gallon model
- Up to 0.93 UEF - 80 gallon model
- Up to 0.90 UEF - 119 gallon model

Integrated Control System

- Digital operating control with LCD display three character for temperature and system monitor - LCD indicators for appliance faults (red light) and operation (green light)
- System parameters password protected
- Outdoor reset
- 120 volt 5 amp electrical connection for condensate pump
- 0-10 volt input for Building Management System
- Dry contact for alarm output
- Outdoor sensor input
- Computer monitor cable allows user to monitor system parameters – fault history – graphical monitor of system operation

Stainless Steel Tank

- Tank construction of 316 L stainless steel
- System return tube with screen for built-in dirt and air separation
- High Temperature Switch
- 1” system return and supply connection for 55 gallon models
- 1 ½” system return and supply connection for 80 and 119 gallon models
- Pressure relief port
- Top and bottom sensor
- Built-in low water cut-off probe

Specialized Features

Standard Phoenix Models

- Offer auxiliary ports for additional applications, including heating through an air handler

Sanitizer Models

- Set to 184°F operating temperature with an adjustable 2°F differential for sanitation purposes

Multi-Fit Models

- Additional top connections and shorter height increase installation flexibility
- 1 ½” system return and supply connections

Additional Features

- Vents in PVC - CPVC - stainless steel – ULC S636 flexible polypropylene vent liner (chimney lining only)
- Vents up to 200 combined equivalent feet in 3” venting (up to 85 combined equivalent feet in 2” venting)
- Built –in condensation system
- Manual reset high limit
- NSF Listed
- Low NOx emissions – SCAQMD Certified
- Lead Free Compliant, as required by the Safe Drinking Water Act, Section 1417

Optional Equipment

- Outdoor Sensor (Part # 7250P-319)
- 2” PVC Concentric Vent Kit (Part # KGAVT0501CVT)
- 3” PVC Concentric Vent Kit (Part # KGAVT0601CVT)
- 2” Stainless Steel Termination Vent Kit (Part # V500)
- 3” Stainless Steel Termination Vent Kit (Part # V1000)
- 4” Stainless Steel Termination Vent Kit (Part # V3000)
- Condensate Neutralizer (Part # 7450P-212)
- PC Connection Cable w / Software (Part # 7250P-738)

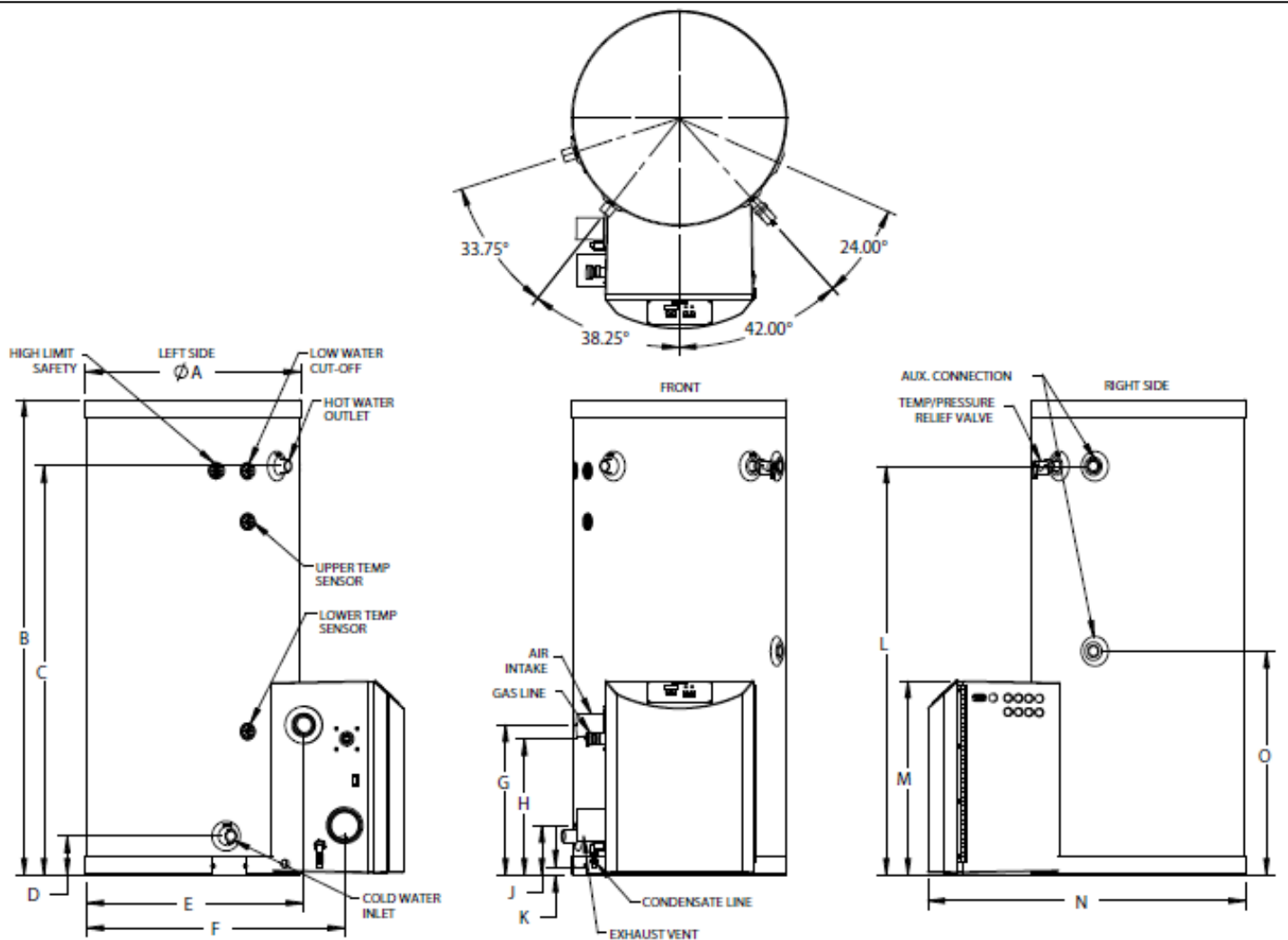

PHOENIX WATER HEATER AND SANITIZER BOOSTER DIMENSIONS

MODEL*	GAL.	A	B	C	D	E	F	G	H	J	K	L	M	N	O
PH100-55/130-55/160-55/199-55	55	23"	52"	45"	5"	23-1/4"	27-3/4"	16-1/4"	14-3/4"	5-1/4"	1"	45"	21"	34-1/4"	27-1/2"
PH100-80/130-80/160-80/199-80	80	23"	72"	64"	5-3/4"	27-1/2"	32"	18-1/2"	17"	7-3/4"	3-1/4"	64"	24-3/4"	34-1/4"	29-3/4"
PH100-119/130-119/160-119/199-119	119	27"	74"	66-1/4"	7-1/2"	27-1/2"	32"	21-1/2"	18-3/4"	10-1/2"	5"	66-1/2"	24-3/4"	38-1/2"	31"
PH199-55SA	55	23"	52"	45"	5"	23-1/4"	27-3/4"	16-1/4"	14-3/4"	5-1/4"	1"	45"	21"	34-1/4"	27-1/2"

PHOENIX WATER HEATER SPECIFICATIONS

MODEL*	INPUT MODULATION	AIR INTAKE/ EXHAUST VENT SIZE	INLET/ OUTLET SIZE	AUXILIARY CONN.	GAS LINE CONN.	SYSTEM RELIEF PIPE SIZE	SHIPPING WEIGHT	MAX. TEMPERATURE LIMIT
PH100-55	30,000 - 100,000	2"	1" NPT	1" FNPT	3/4"	3/4"	175 LBS.	160°
PH130-55	30,000 - 130,000	2"	1" NPT	1" FNPT	3/4"	3/4"	175 LBS.	160°
PH160-55	40,000 - 160,000	3"	1" NPT	1" FNPT	3/4"	3/4"	175 LBS.	160°
PH199-55	40,000 - 199,000	3"	1" NPT	1" FNPT	3/4"	3/4"	175 LBS.	160°
PH100-80	30,000 - 100,000	2"	1-1/2" NPT	1" FNPT	3/4"	3/4"	235 LBS.	160°
PH130-80	30,000 - 130,000	2"	1-1/2" NPT	1" FNPT	3/4"	3/4"	235 LBS.	160°
PH160-80	40,000 - 160,000	3"	1-1/2" NPT	1" FNPT	3/4"	3/4"	235 LBS.	160°
PH199-80	40,000 - 199,000	3"	1-1/2" NPT	1" FNPT	3/4"	3/4"	235 LBS.	160°
PH100-119	30000 - 100,000	2"	1-1/2" NPT	1" FNPT	3/4"	3/4"	405 LBS.	160°
PH130-119	30,000 - 130,000	2"	1-1/2" NPT	1" FNPT	3/4"	3/4"	405 LBS.	160°
PH160-119	40,000 - 160,000	3"	1-1/2" NPT	1" FNPT	3/4"	3/4"	405 LBS.	160°
PH199-119	40,000 - 199,000	3"	1-1/2" NPT	1" FNPT	3/4"	3/4"	405 LBS.	160°

PHOENIX SANITIZER BOOSTER SPECIFICATIONS

PH-199-55SA	40,000 - 199,000	3"	1"	1" FNPT	3/4"	3/4"	175 LBS.	184°
-------------	------------------	----	----	---------	------	------	----------	------

*ALL DIMENSIONS ARE APPROXIMATE, A SUFFIX OF "LP" DENOTES PROPANE GAS

LP-179-B
03/09/18

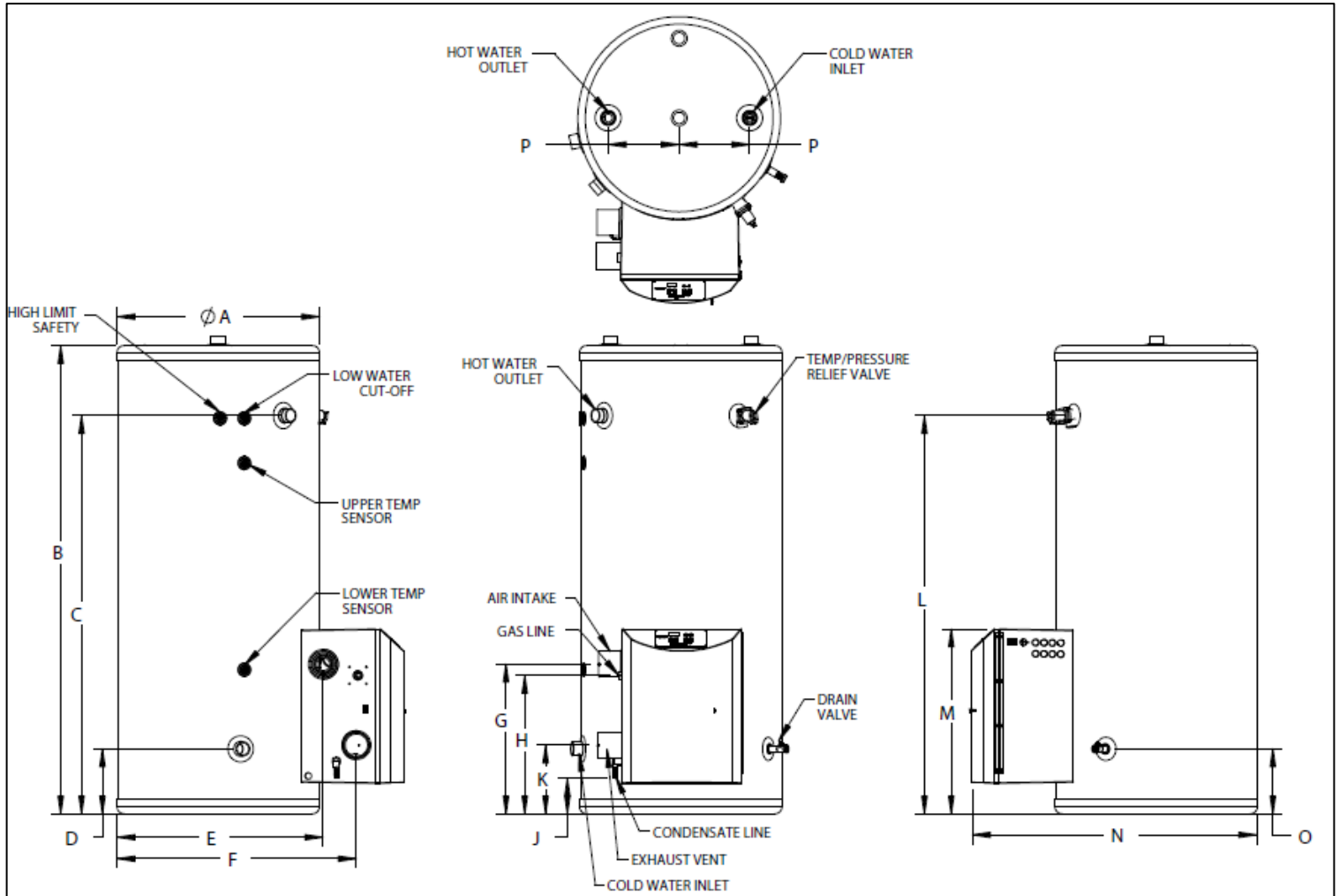

PHOENIX MULTI FIT WATER HEATER

MODEL*	GAL.	A	B	C	D	E	F	G	H	J	K	L	M	N	O	P
PHM130-80/199-80	80	27"	55"	45-1/4"	7-1/4"	27-1/2"	32"	18-1/4"	17"	3"	8"	45-1/4"	24-3/4"	38-1/4"	7-1/4"	9-1/2"
PHM130-100/199-100	100	27"	63"	54"	7-1/4"	27-1/2"	32"	18-1/4"	17"	3"	8"	54"	24-3/4"	38-1/4"	7-1/4"	9-1/2"

PHOENIX MULTI FIT WATER HEATER SPECIFICATION

MODEL*	INPUT MODULATION	AIR INTAKE/ EXHAUST VENT SIZE	INLET/ OUTLET SIZE	GAS LINE CONN.	SYSTEM RELIEF PIPE SIZE	SHIPPING WEIGHT	MAX. TEMPERATURE LIMIT
PHM130-80	30,000 - 130,000	2"	1-1/2" NPT	3/4"	3/4"	285 LBS	160°
PHM199-80	40,000 - 199,000	3"	1-1/2" NPT	3/4"	3/4"	285 LBS.	160°
PHM130-100	30,000 - 130,000	2"	1-1/2" NPT	3/4"	3/4"	315 LBS.	160°
PHM199-100	40,000 - 199,000	3"	1-1/2" NPT	3/4"	3/4"	315 LBS.	160°

*ALL DIMENSIONS ARE APPROXIMATE, A SUFFIX OF "LP" DENOTES PROPANE GAS, "M" DENOTES MULTI FIT MODEL

LP-179-B
11/15/18

PERFORMANCE SPECIFICATIONS FOR PHOENIX MODELS

BTUH	Thermal Efficiency (TE)	Temperature Rise											
		(°F)	40	50	60	70	80	90	100	110	120	130	140
		(°C)	22	28	33	39	44	50	56	61	67	72	78
100,000	96%	GPH	298	240	202	173	152	136	123	110	101	94	88
		GPM	5	4	3.4	2.9	2.5	2.25	2	1.8	1.7	1.6	1.5
		LPH	1128	908	765	655	575	515	466	416	382	356	333
		LPM	18.8	15.1	12.75	10.9	9.6	8.6	7.8	6.9	6.4	5.9	5.6
130,000	96%	GPH	384	309	260	222	195	175	158	141	130	120	112
		GPM	6.4	5.2	4.3	3.7	3.25	2.9	2.6	2.4	2.2	2	1.9
		LPH	1454	1170	984	840	738	662	598	534	492	454	424
		LPM	24.25	19.5	16.4	14	12.3	11	10	8.9	8.2	7.6	7
160,000	96%	GPH	470	378	317	271	238	213	192	173	159	147	137
		GPM	7.8	6.3	5.3	4.5	4	3.6	3.2	2.9	2.7	2.5	2.3
		LPH	1779	1431	1200	1026	901	806	727	655	602	556	519
		LPM	29.7	23.9	20	17.1	15	13.4	12.1	10.9	10	9.3	8.7
199,000	96%	GPH	582	468	392	335	294	263	237	213	196	181	169
		GPM	9.7	7.8	6.5	5.6	4.9	4.4	4	3.6	3.3	3	2.8
		LPH	2203	1772	1484	1268	1113	996	897	806	742	685	640
		LPM	36.7	29.5	24.7	21.1	18.6	16.6	15	13.4	12.4	11.4	10.7

Recovery on rating plate is based at 94% thermal efficiency at 70° Fahrenheit rise, as required by ANSI

Model #	Uniform Energy Factor (UEF)
100-55	0.89
100-80	0.93
100-119	0.90

Uniform Energy Factor (UEF) – Applicable to 100kBTU Models Only